

LOCAL ROAD

STANDARD PAVING SECTION

SCALE: N.T.S.

RURAL

URBAN

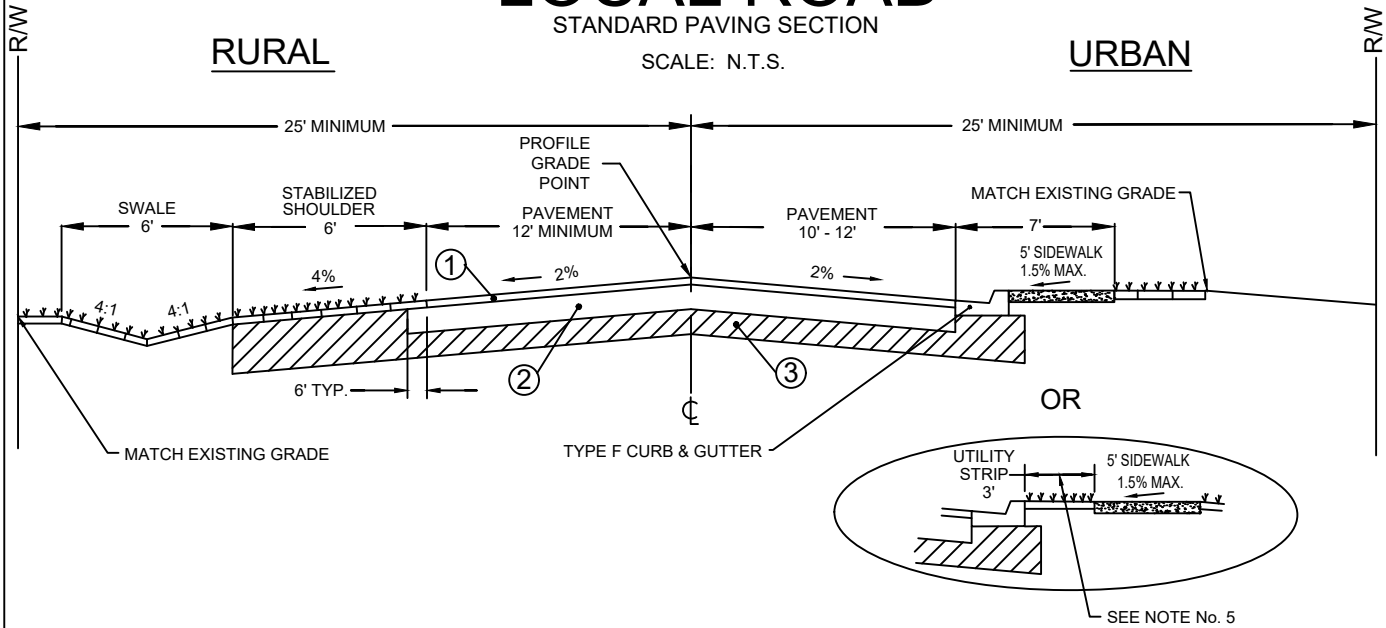

KEY:	THICKNESS:	
1	1 1/2"	STRUCTURAL ASPHALT (SP 9.5) PER FDOT SPECIFICATIONS.
2	6"	LIMEROCK - 98% COMPACTION, .A.S.H.T.O. T-180, PRIMED & SANDED. (LBR 100)
3	12"	TYPE B STABILIZED SUBGRADE LBR MIN. 40, 98% COMPACTION, A.A.S.H.T.O. T-180.

NOTE:

- ALL STRIPING TO BE LEAD & SOLVENT FREE THERMOPLASTIC IN ACCORDANCE WITH FDOT SPECIFICATION 711 UNLESS OTHERWISE NOTED.
- SOD ALL DISTURBED AREAS.
- MAXIMUM DESIGN SPEED IS 25 MPH.
- FOR SUPERPAVE UTILIZE TRAFFIC LEVEL B.
- MINIMUM 4 FEET SEPARATION FOR ROADWAYS WITHOUT 6" RAISED CURB.
- ANY ROADWAY TURNED OVER TO THE CITY OF LEESBURG MUST COMPLY WITH MATERIALS TESTING AND INSPECTION DURING CONSTRUCTION.

STORMWATER INSPECTION SERVICES:

- MATERIAL AND STRUCTURE INSTALLATION.
 - COMPACTION TEST REPORTS FOR PIPE RUNS AND STRUCTURES IN THE ROW REQUIRED.
- LAMPING AND CERTIFICATION BY ENGINEER OF RECORD.

ROADWAY INSPECTION SERVICES:

- STABILIZED SUBGRADE TO BE STRING LINED WITH LBRs AND DENSITY TESTING REQUIRED.
- BASE TO BE STRING LINED WITH LBRs, AND DENSITY TESTING REQUIRED.
- CONCRETE TO INCLUDE SIDEWALKS, CURBS AND RAMPS.
- PAVEMENT
 - ASPHALT MIX DESIGNS TO BE PROVIDED AND APPROVED BY THE CITY.
 - CONTRACTOR TO PROVIDE QC TESTING AND ASPHALT REPORTS TO INCLUDE SPREAD RATE.
 - COPIES OF DELIVERY TICKETS WITH MIX DESIGN NUMBER REFERENCE INCLUDED TO BE PROVIDED.
- TRAFFIC SIGNAGE & PAVEMENT MARKINGS.
- FINAL INSPECTION.



LEESBURG
The Lakefront City

City of Leesburg
Standard Details

2024

DETAIL ST-1